

Cognitive dysfunction in non-demented Parkinson's disease

R. COOLS, R. SWAINSON, A.M. OWEN and T.W. ROBBINS

ABSTRACT

We surveyed deficits in attentional set-shifting, working memory and planning in patients at different stages of Parkinson's disease (PD). These functions are all sensitive to frontal lobe damage and exhibit considerable selectivity. Thus, the attentional set-shifting deficit is paralleled by impairments in task set-shifting, uncontaminated by learning. The working memory deficits are found more readily in the spatial domain. Recent evidence of both positive and deleterious effects of dopaminergic medication is reviewed. Finally, the neural substrates of cognitive deficits in PD and their response to medication is surveyed in a functional neuroimaging context.

INTRODUCTION

In our previous review in 'Mental Dysfunction in Parkinson's Disease' (1) the close neuropsychological relationship between frontal lobe damage and Parkinson's disease (PD) was considered. In one approach, medicated and non-medicated PD patients at various stages of the disease were compared with frontal lobe patients. In a second approach, PD patients were compared with several groups of patients with basal ganglia disorders (Progressive Supranuclear Palsy (PSP) and Multiple System Atrophy (MSA)). We mainly focused on three tests sensitive to frontal lobe damage. The Tower of London (2) was used to test planning ability, while the Spatial Working Memory test and a test of attentional set-shifting were used to assess different aspects of executive function. Although informative qualitative differences between the groups were found, it was concluded that PD patients in the early stages of their disease show a pattern of cognitive deficits which is more similar to those of patients with frontal lobe damage than those of temporal lobe excision patients, while PD patients in the later stages of their disease also show temporal lobe-like deficits. Thus patients with PD exhibit a distinct set of cognitive deficits early in the course of the disease which contrasts with those seen, for example, in Alzheimer's disease. Only later in the course of PD do the cognitive deficits begin to overlap with those of the classical cortical dementias.

The present review represents an update of the previous one, presenting further results obtained for PD patients in the cognitive domains of planning, working memory and attentional set-shifting.

ATTENTIONAL SET-SHIFTING

Shifting attentional set involves altering the rules which are currently guiding behaviour, where attentional set can be defined as a learned predisposition to attend to one dimension of multidimensional stimuli in order to guide subsequent responding. In many studies a deficit in set-shifting has been found in PD, using a number of different paradigms (among others the Wisconsin Card Sorting Test (WCST; (3)) (4-12). The precise nature of the set-shifting deficit remains unclear. Several authors disagree on the crucial components of the impairment and a major debate in the literature concerns the nature of the cognitive processes underlying the set-shifting deficit in PD.

Downes *et al* (13) used a paradigm derived from the animal and human learning literature to assess attentional set-shifting and reversal shifting in both medicated and non-medicated patients with PD. The test was devised to decompose the WCST, in which set-shifting is supposed to be a central component of performance. Performance on the WCST, they argued, involves, among others, the following cognitive abilities: (a) matching to sample; (b) conditional visuospatial learning contingencies (set-formation) and (c) inhibition of responding to a particular dimension and shifting to responding to another dimension. In their paradigm, discrimination learning, reversal shifting, intradimensional shifting (IDS) (in which shifts are made to different exemplars of the same rule or perceptual dimension) and extradimensional shifting (EDS) (in which shifts are to different perceptual dimensions) can be separately investigated. The ID/ED task has been extensively described in previous papers (13,14) and we refer the reader to those descriptions. Downes *et al* (13) provided evidence for a specific EDS deficit in PD, relative to other forms of shift, such as reversal and the IDS. Non-medicated mild PD patients also showed difficulties in learning a compound discrimination (CD). Owen *et al* (15) replicated the finding of a parkinsonian deficit on the ID/ED task. However, in this study impairments for non-medicated PD were not specifically limited to the EDS stage, also being evident in earlier stages of the task. In both studies, non-medicated patients performed more poorly, but not significantly so, than medicated PD patients, hinting at a beneficial effect of dopaminergic medication on attentional set-shifting. A study by Lange *et al* (16) provided further evidence for such an effect. Nine out of ten PD patients reached a later stage in the ID/ED shift task when on-medication as compared to their off-medication state. However, it is unclear from this study whether the deficit was specific to the EDS stage, because many patients failed earlier stages in their off-medication stage.

In a recent study (17) support was found for a *specific* EDS deficit, in terms of both percentage of failures and number of errors, in mild PD patients. No impairments were found at other stages. These patients were divided into three groups according to their Hoehn and Yahr scores (1, 2 and 3). Results from that study showed an *improvement* in EDS performance with increased severity of PD. The more severe the symptoms of the patients, the better

they performed on the task, and particularly at the EDS stage. At first glance, these findings seem to contradict results from Owen *et al* (15). They found severe PD patients to be much more impaired than milder patients (although this effect did not reach significance). However, it must be noted that all patients in the Cools *et al* study (17) were still in relatively mild stages of their disease (Hoehn and Yahr I - III). Furthermore, the duration of the disease correlated significantly with Hoehn and Yahr ratings. Thus, such PD patients would have been taking medication for a longer period. It is therefore hypothesised that the seemingly severity-related improvement in performance on the ID/ED task actually may reflect an effect of medication. The notion that medication improves shifting-performance is consistent with previous findings (4,13,15,16,18,19,20). It must be noted that sample sizes were small when the PD group was subdivided according to severity. Nevertheless, it can be concluded that, in the context of previous results, this study supports the above mentioned hypothesis. In a study by Owen *et al* (14) a frontal lobe group was selectively impaired at the EDS stage, while temporal lobe patients and patients with amygdalo-hippocampectomy were unimpaired in their ability to shift to a previously irrelevant dimension. Together with the finding that patients with Huntington's disease (21,22) are impaired at the EDS stage, these results strongly suggest that dysfunctioning fronto-striatal mechanisms are involved in the parkinsonian EDS impairment. Fig. 1 shows the comparative performance of patients with frontal and temporal lobe lesions, medicated mild and severe PD patients and non-medicated PD patients. The most severe EDS impairments were seen in the severe medicated PD patients. Severe impairments were also seen in the non-medicated PD group, although deficits in this group were not limited to the EDS stage. The mild medicated PD group performed very similarly to the frontal lobe patients, while patients with temporal lobe excisions were found to be unimpaired.

AN IMPAIRMENT IN SET SHIFTING: LEARNED IRRELEVANCE OR PERSEVERATION?

Owen *et al* (23) directly compared medicated and non-medicated PD patients with patients with frontal lobe excisions. They designed a different version of the ID/ED task, in which they distinguished a "perseveration condition" and a "learned irrelevance condition". They defined perseveration as "the inability to shift from a perceptual dimension which has previously been irrelevant". In the "learned irrelevance condition" the previously *relevant* dimension was substituted for a novel dimension. Thus, in this condition any impairment could not be a consequence of perseveration. The authors argue, therefore, that any impairment can only be a consequence of learned irrelevance. In the "perseveration condition" the previously *irrelevant* dimension was substituted for a novel one. Therefore, any impairment must be due to perseveration and not learned irrelevance. Non-medicated patients with PD were equally impaired in both conditions. Medicated PD patients were only impaired in the "learned irrelevance condition", but not

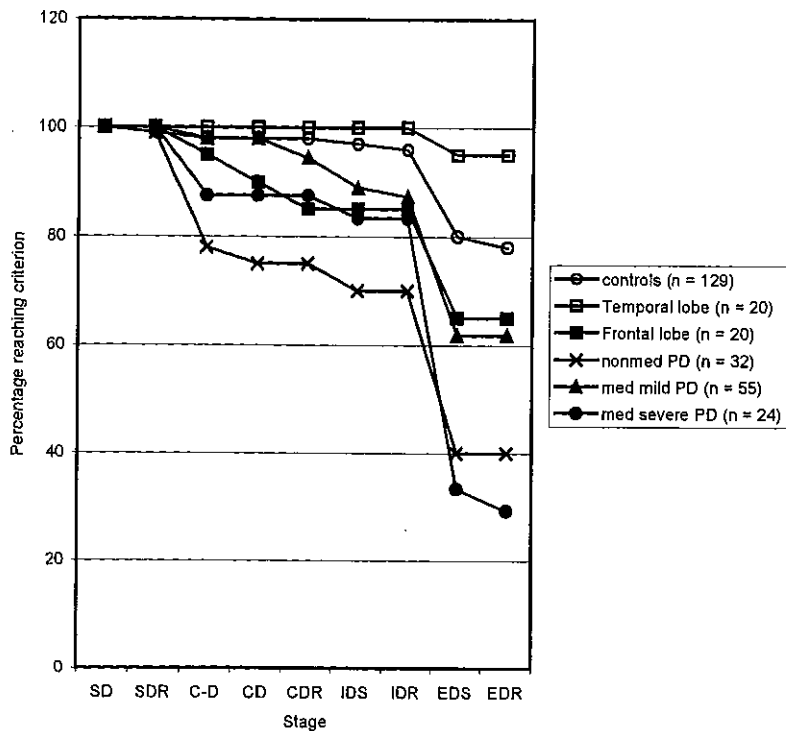

Fig. 1. Proportion of subjects successfully passing each stage of the attentional set-shifting task. Control subjects, frontal, temporal, mild non-medicated PD (nonmed PD), mild medicated PD (med mild PD) and severe medicated PD (med severe PD) patients are shown. Abbreviations: SD'simple discrimination; SDR 'simple reversal; C-D 'compound discrimination (with spatially separate shapes and lines); CD'compound discrimination (lines superimposed on shapes); CDR'compound reversal; IDS'intradimensional shift; IDR'intradimensional shift reversal; EDS'extradimensional shift; EDR'extradimensional shift reversal.

in the "perseveration condition". Patients with frontal lobe damage showed the opposite pattern of deficits: increased levels of "perseveration", but normal levels of "learned irrelevance". These differences were found exclusively at the EDS (+ ED reversal) stages. All patients were unimpaired at the IDS and ID reversal stages. The authors suggest that the deficit in medicated PD patients (the "learned irrelevance" deficit), which is opposite to the deficit seen in patients with frontal lobe damage, involves a dysfunctioning of circuitry *not* involving the prefrontal cortex. Furthermore, non-medicated patients with PD also showed a "frontal-like" perseverative tendency, as well as enhanced learned irrelevance. On this basis it was suggested that L-dopa medication ameliorated the perseveration deficit in the medicated PD group relative to the non-medicated group but not the learned irrelevance deficit. Similar shift conditions were used by Gauntlett-Gilbert *et al* (24) to detect perseveration or learned

irrelevance deficits in mild medicated PD patients. Their mild patients performed badly compared to controls in a condition in which an impairment could only be a consequence of enhanced learned irrelevance, but not perseveration. They also performed badly on a condition in which perseveration had to account for the impairment. Moreover, patients performed more poorly in another condition in which enhanced learned irrelevance should have led to an improvement in performance. Based on these results, it was concluded that PD patients are impaired in shifting *per se*, but that learned irrelevance could not account for these results. This result appears to be in contrast to Owen *et al*'s results (23) in medicated PD patients who were impaired in the learned irrelevance condition, but not in the perseveration condition. However, Owen *et al*'s (23) mild medicated patients were in more severe stages of their disease than the mild medicated patients in the Gauntlett-Gilbert *et al* study (24) in terms of severity. Indeed, the medicated patients in the Gauntlett-Gilbert *et al* study (24) performed similarly to the non-medicated patients in the Owen *et al* study (23). Both groups showed bad performance in both the learned irrelevance and the perseveration condition. Moreover, the patterns in PD patients in both studies were different from that of frontal lobe patients, who only showed perseveration.

REVERSAL SHIFTING

Another form of cognitive flexibility is in shifting rules at the level of stimulus-response/reinforcer mappings instead of at the superordinate level of attentional set. This form of flexibility is required in reversal tasks, where the reinforcement contingencies of stimuli which had been originally learned are reversed. The question of whether the shifting deficit in PD is restricted to ED shifting (13,17,23) or extends to reversal shifts (15,25) has recently been addressed by Swainson *et al* (26). They hypothesised, on the basis of findings in animal studies (27), anatomical facts (28) and findings in studies of other patient groups (29), that EDS would be more vulnerable than reversal shifting in mild PD. The possibility that a ceiling effect played a role in previous studies, in which no reversal deficits were found, was overcome by increasing the difficulty level of the tasks. Learning and reversal of probabilistic and concurrent discriminations were investigated in mild non-medicated PD patients, mild medicated PD patients, severe medicated PD patients, patients with frontal lobe lesions (FLL) and patients with temporal lobe lesions (TLL). The cortical patients were impaired in the reversal of both discriminations. The mild non-medicated PD group was *unimpaired* in both reversal tasks, while both medicated PD groups both showed (non-perseverative) reversal impairments. This result was hypothesised to be a consequence of either medication overdose (there was a significant correlation of error and dose of medication) or a disease severity effect. Gotham *et al* (30) had earlier proposed the "dopamine-overdose hypothesis", which was elaborated by Swainson *et al* (26). Anatomical findings from Kish *et al* (31) led them to suppose that the levels

Cortico-basal ganglia-thalamo-cortical loops:

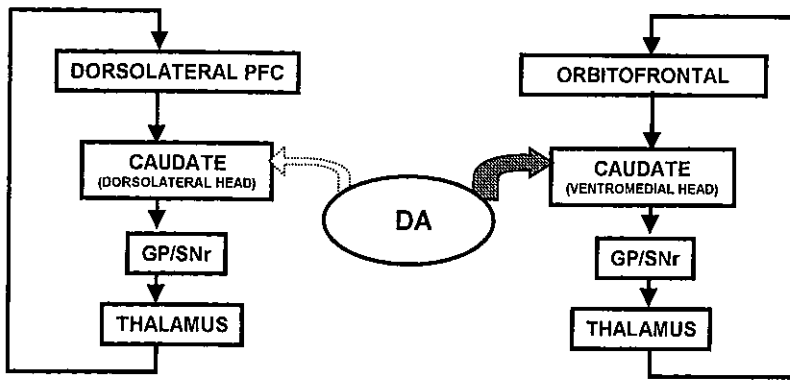

Proposed effects of medicated dopamine levels on cognitive functions of loops:

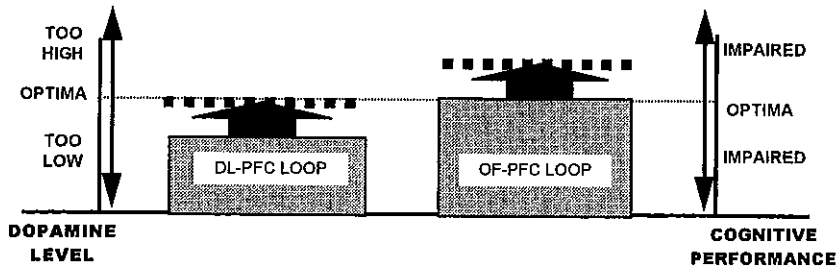

Fig. 2. The dopamine 'overdose' hypothesis applied to cognitive function within cortico-basal ganglia circuits. Dopamine (DA) depletion severe enough to produce functional deficits may be present only in the most dorsal, rostral aspect of the head of the caudate nucleus – affecting only dorsolateral prefrontal loop. Medication will bring DA levels in this loop towards the optimal level and result in beneficial effects on set-shifting. Introducing dopaminergic medication to the less affected ventromedial head of the caudate nucleus (part of the orbitofrontal loop) may push the amount of dopaminergic activity above the optimal level, impairing performance on tasks, such as reversal, which utilise this circuit. DL-PFC – dorsolateral prefrontal cortex; OF-PFC – lateral orbitofrontal cortex; (dl-h) – dorsolateral head, (vm-h) – ventromedial head of caudate; Gpi/SNr – internal pallidum/substantia nigra pars reticula.

..... level of function following introduction of medication

of dopamine depletion in the putamen and only the dorsal, rostral part of the head of the caudate nucleus were sufficient to produce functional deficits as opposed to levels of depletion in the more ventral parts of the caudate nucleus. Administration of dopaminergic medication may therefore produce beneficial effects on the motor and the dorsolateral prefrontal 'loops', but detrimental effects on the functioning of the orbitofrontal 'loop' (see Fig. 2). The associations of the dorsolateral

prefrontal 'loop' with attentional set-shifting and the orbitofrontal 'loop' with reversal shifting is compatible with this hypothesis (27,32).

In the study by Swainson *et al* (26), both medicated PD groups showed a nonsignificant tendency to fail to maintain the probabilistic discrimination at the acquisition stage (as measured by the proportion of errors made subsequent to criterion being reached). Additionally, among mild medicated PD patients, the number of maintenance errors made in the probability reversal task correlated significantly with errors at reversal. These results, together with the non-perseverative nature of the reversal errors in the medicated PD groups, raise the question whether this deficit at the reversal stage represented a specific impairment in shifting or a more generalised impairment in learning new contingencies.

SET-FORMATION OR SET-SHIFTING?

Set-formation involves associative learning and several studies have shown deficits in such learning in PD (33,34). However, other studies (12,35) have found the acquisition of attentional sets to be intact. Swainson (36) has argued for the possibility that the deficit found in set-shifting tasks is the result of impairments in rule-learning. In short, many investigations did not control for possible learning-deficits by failing to use an adequate baseline measure. For example, in several such studies using the WCST, data regarding initial acquisition have either been not collected or not reported. In other cases, the initial relevant dimension was determined by the first choice of the subject. Consequently, it is difficult to conclude whether the disease is characterised by impairments in shifting or rule-learning. Notably, Downes *et al* (13) found that non-medicated PD patients had significant difficulties at the CD stage of the ID/ED task, at which point the appropriate attentional set is still being developed.

Conditional rule-learning has been related to the frontal lobes (37), but the role of the striatum in learning is less clear. Wise (38) provided a critique of the habit-learning-hypothesis of striatal functions which states that the basal ganglia subserve procedural learning and nondeclarative memory. Although some authors have argued for a disruption of acquisition of visual discriminations by striatal lesions in animals, closer inspection suggested only minor retardations in the rate of acquisition, with associative processes and memory being intact (38). Wise (38) proposed an alternative hypothesis of a modulatory role for the basal ganglia in rule-learning, which is principally mediated by the frontal lobes. Robbins and Brown (39) also suggested striatal inhibitory and facilitatory effects of dopamine activity ('set-related' activities) on cortical inputs. The main function of the striatum was identified as one of response regulating selection or 'set', in the control of attention. The formation of 'set' can be seen as an important contribution to procedural learning, by facilitating the association of certain inputs with certain outputs. However, it is difficult to be sure whether deficits in set formation are caused in part by other problems of set regulation, e.g. shifting, or whether (as suggested above (36)) the apparent

set-shifting problems are a product of deficient learning. To tease apart these factors, which are inherent in all novel tasks such as the WCST or the ID/ED, it is necessary to utilise a set-shifting task in which new learning is minimised and so the set-shifting component is at a premium.

TASK SWITCHING

Apart from the ID/ED shift paradigm, the task-switching paradigm, which was derived from human experimental psychology (first devised by Jersild (40) in 1927), is also suitable for investigating the flexibility of cognitive set. In general, to perform a task, a configuration of perceptual, cognitive and response processes must be linked together and this so-called task-set is responsible for accomplishing a certain task. Repetitive changes in the environment require constant switching between those sets of operations or in other words, constant task-set reconfigurations. In the task-set switching paradigm, subjects have to switch responding between consistent stimulus-response mappings that have been previously well-learned. Because these stimulus-response mappings are well-learned, switching-deficits can be *isolated* from those of learning per se. Therefore, it makes a suitable paradigm with which to investigate whether PD is mainly characterised by shifting or learning deficits, as opposed to the ID/ED task, in which poor performance can be a consequence of both learning and shifting impairments.

An "alternating-runs" task, devised by Rogers and Monsell (41), was used to study task-set switching in patients with left- and right-sided frontal damage and medicated mild PD patients (42). Subjects were required to switch between letter- and digit-naming tasks on every second trial. Switch-costs were calculated by subtracting performance (reaction times and errors) on nonswitch-trials from performance on switch-trials. Each stimulus consisted of two closely adjacent characters presented side by side. In the letter-naming task, one of the characters was a letter (randomly presented on the left or the right of the stimulus pair) and subjects were required to name the letter as fast as possible without making a mistake. In the digit-naming task, one of the characters was a digit (randomly presented on the left or the right of the stimulus pair) and subjects were required to name the digit as fast as possible without making a mistake. Furthermore, the strength of task cues was manipulated. In the relatively weak and arbitrary colour cue-manipulation, the colour of the stimulus-window indicated the relevant task. In the relatively strong word cue-manipulation, the word "letter" or "number" was printed at the top of the stimulus-window. The design included 'crosstalk' and 'no-crosstalk'-conditions. In the no-crosstalk-condition, the stimulus consisted of attributes which were only associated with the relevant task. The irrelevant character was a neutral, non-alphanumeric character. In this condition, filtering of irrelevant information is not needed to perform well on the task. In the crosstalk-condition, the irrelevant character was on the majority of trials associated with the competing, irrelevant (letter- or digit-naming) task.

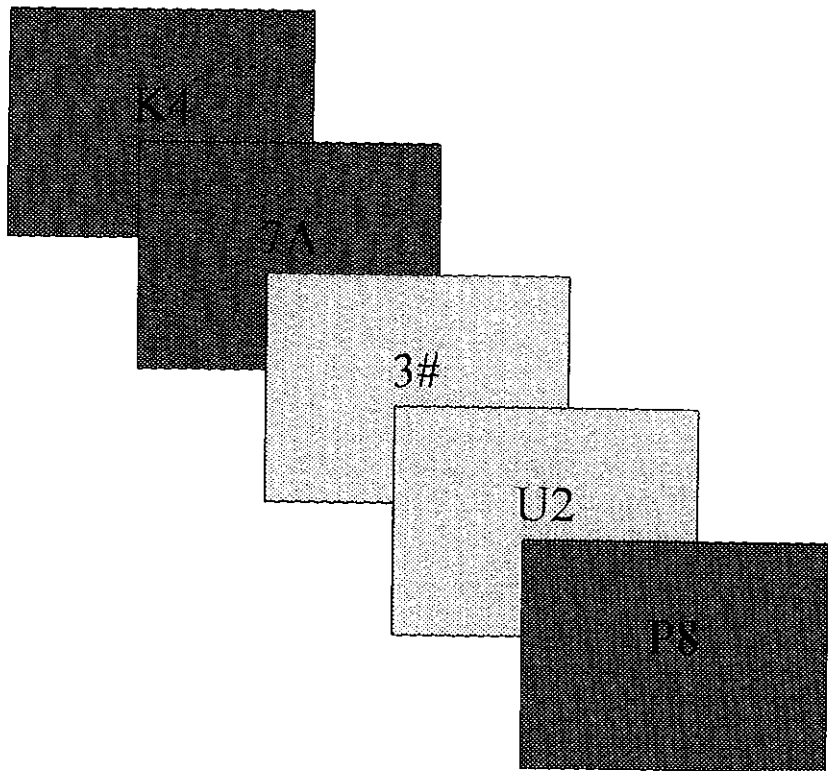

Fig. 3. An example of a trial-sequence in the crosstalk-condition in the switching task.

Thus, in this case the stimulus contained both a letter and a digit. On these trials filtering of irrelevant information was needed to perform well on this task. Fig. 3 shows an example of a colour-cued trial-sequence in the crosstalk-condition, in which most stimuli included task-associated irrelevant characters.

In the study by Rogers *et al* (42) patients with left-sided frontal damage, but not patients with right-sided frontal damage, nor PD patients, showed increased switch-costs compared to matched controls. This increase in frontal lobe patients only occurred in the crosstalk-condition and particularly, when subjects had to use the weak colour-cues. Both groups of frontal patients, but not the PD patients, showed disorganised behaviour during practice-blocks, in which task-sets were acquired. Although PD patients did not show increased switch-costs, they *did* show progressively increasing error-costs as the task proceeded, while error-costs in controls decreased. From the above results it was concluded that left frontal lesions impair acquisition and switching of task-sets, while PD patients only showed progressively increased error-costs, possibly indicating fatigue-processes.

Somewhat different results were obtained by Hayes *et al* (43). They examined switching in a cognitive task, in which colour-shape switches were required. On each trial, 2 stimuli, either unidimensional or bidimensional, appeared sequentially and subjects had to respond to either colour or shape according to a simultaneously presented dimension-instruction. On half of the trials a switch was required, on the other half of the trials no switch was required. After each trial, there was a 500 msec interval, followed by a 1 sec-message, saying "next trial". Thus, switching in this task is different from the moment-by-moment reconfiguration in the above-mentioned study. Whether or not it had been necessary to switch dimensions for the second stimulus in the previous trial affected the performance for the first stimulus in the following trial was not considered and presumably regarded as unimportant. In one experiment, the performance of PD patients was compared to that of controls. In another experiment, the performance of PD patients in the on-medication state was compared to that of PD patients in the off-medication state. Switch-costs were found to be larger in PD patients than in controls. The effect of the presence of the irrelevant stimulus attributes on performance in general and switching in particular was tested to investigate the efficiency of filtering the irrelevant dimension. RT-analyses showed no effect on switching, but errors were not analysed. The presence of the irrelevant dimension *did* have an effect on performance in general (in both switch- and non-switch-trials), this effect being significantly greater in PD patients. Patients off-L-dopa showed significantly higher switch-costs (in both RT and errors) than patients on-L-dopa. In summary, this study showed an impairment in (discontinuous) switching in PD. Furthermore, PD patients had difficulty filtering the irrelevant dimension. The data also suggested a beneficial effect of medication on switching.

Although no significant switch-effects for PD patients were found by Rogers *et al* (42), there was a tendency to perform worse under certain experimental conditions (i.e. in the crosstalk-condition). In a later study (17) a shorter version with only the arbitrary colour-cue conditions of the paradigm was used in order to reassess a larger sample of mild to moderate PD patients. In this study, the PD patients showed significantly increased switch-costs, in terms of reaction times, and particularly in the crosstalk-condition (Fig. 4).

The sample size, and thus the statistical power, in this study was much larger than in the previous study in PD and this may account for the difference in results. Moreover, this study avoided further contamination of effect from other parts of the design which may have blunted the effect on switching in the PD group. Although patients in the study by Rogers *et al* (42) were in an earlier stage of their disease than the patients in the study by Cools *et al* (17), severity of the disease alone could not account for the difference in results, because the more severe patients actually showed smaller switch-costs than the milder patients in the recent study. A similar argument can be advanced to explain this superficially severity-related improvement in performance on task-switching as for the previously

The Switch-effect in the Crosstalk-condition

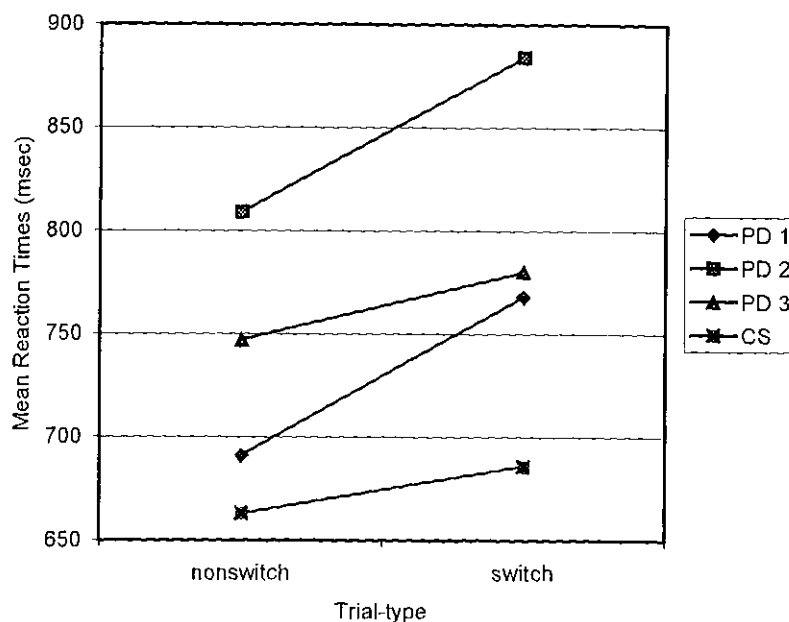

Fig. 4. Mean reaction times on task-switching in the crosstalk-condition. Abbreviations: PD 1 ' patients with Parkinson's disease in Hoehn and Yahr stage 1.0; PD 2 ' patients with Parkinson's disease in Hoehn and Yahr stage 2.0; PD 3 ' patients with Hoehn and Yahr stage 2.5; CS ' control subjects

mentioned results on the ID/ED task. The deficit in switching task-sets was particularly pronounced in the two mildest patient groups. Switch-costs declined with increased severity and duration of disease, which possibly reflects a medication effect. Hayes *et al* (41) indeed found non-medicated PD patients to show larger switch-costs than medicated patients in a similar paradigm. In summary, these results suggest that the striatal dopaminergic deficit is indeed involved in the parkinsonian switching-impairment.

The earlier mentioned results on ID/ED shifting by Cools *et al* (17) were collected from the same patient group as these results on task-set switching. Together, these results are incompatible with the hypothesis that the attentional set-shifting deficit is simply a consequence of an impairment in learning or set-formation (36). Because task-sets in the task-set switching paradigm are well-learned beforehand, the switching-deficit can be isolated from that of learning *per se*. Results for task-set switching in PD resemble those seen in frontal lobe patients. Moreover, the results indicate an involvement of a dopaminergic deficit in the parkinsonian switching impairment. Together with recent findings that patients with Huntington's disease showed similar increased switch-costs (Watkins *et al*, unpublished

data), these results strongly indicate the involvement of fronto-striatal circuits in task-set switching.

SPATIAL WORKING MEMORY

Many studies have investigated working memory (WM) in PD. Patients with temporal or frontal lobe lesions and medicated mild and severe PD patients have been shown to be impaired in terms of accuracy on a self-ordered spatial WM task (44-46). In this task, subjects are required to find 'tokens' by searching through a number of boxes, while avoiding boxes in which tokens had previously been found. Non-medicated PD patients have been found to be unimpaired on this self-ordered spatial WM task (15, 46) while they were found to be impaired on another, more sensitive, sequencing task (described below) (48). Although frontal lobe patients have been found to use fewer effective searching strategies than controls, temporal lobe patients, patients with amygdalo-hippocampectomy, but also medicated PD patients seemed to utilise normal, effective searching strategies in this task (15,45). The results for temporal lobe patients and patients with amygdalo-hippocampectomy suggested the medial temporal lobe to be involved in mnemonic components of this search task, whereas results for the frontal lobe patients indicated the frontal lobe to be involved in more strategic components of the task. A strategy for enhancing performance was not obvious in an analogous visual search with a high load on WM (recall of abstract patterns). The finding that patients with frontal lobe damage were unimpaired, while patients with temporal lobe damage and amygdalo-hippocampectomy were impaired (45), is consistent with different roles in such tasks for the frontal and the medial temporal lobes.

The finding that PD patients showed a WM deficit without a large strategy deficit is surprising in the context of previous results (49). A possible explanation is that dopaminergic medication beneficially affected this frontal deficit in PD. A more recent study (50) used a different WM task to study the utilisation of strategies, following training. In this visuospatial sequencing task, performance was much more dependent upon the use of efficient strategies. The task consisted of a pre-training test-stage, a training block and a post-training test-stage. Comparison of performance in the first and the last stage enabled the testing of the effect of training and strategy-cuing. In one experiment, the strategy was relatively weakly cued. Young medicated and non-medicated PD patients, frontal lobe patients, but not temporal lobe patients, performed worse at stage 2 than controls, while all these patients showed intact baseline WM performance at stage 1. The impairment at stage 2 in PD patients and frontal lobe patients could be (at least partly) explained by a lack of strategy use. In another experiment (50) in which the strategy was made even more explicit, young medicated PD patients and frontal lobe patients were able to implement this cued strategy and no impairment was seen in post-training tests, training blocks or strategy score. Only the old PD group was still impaired, suggesting additional problems in spatial WM. Similar results were found using a

verbal memory task, in which it was investigated whether a lack of semantic strategy usage could account for impairments. Young PD medicated patients (non-medicated patients were not tested) and frontal lobe subjects again showed no impairments in baseline verbal recall, as measured in a pre-training test-stage, but they were impaired in using a training block, in which strategies were made explicit, to improve their performance at a post-training test-stage. Again, old PD patients showed baseline impairments. These results are consistent with a role for fronto-striatal circuitries in the strategic control of mnemonic performance.

West *et al* (51) assessed mild medicated PD patients on the Self-Ordered Pointing Task (52) and found errors to be mainly clustered at the end of trials. Because demands on strategic processes increased within a trial, it was concluded that the deficit reflected a failure to coordinate activities of WM, rather than a decline in the structural or operational capacity of this system.

The hypothesis that cognitive deficits in PD progress from 'frontal' deficits to more 'posterior' cortical deficits was supported in a study in which PD patients were compared on tasks of spatial, visual and verbal WM (53). As described above, the spatial (search) WM task, but not the visual (search) WM task was found to be sensitive to frontal lobe damage, while both the spatial and visual WM task were found to be sensitive to temporal lobe damage. Owen *et al* (53) found non-medicated mild PD patients to be unimpaired on spatial WM, visual WM as well as verbal WM. Medicated mild PD patients were found to be impaired only on the spatial WM task, but not on the other two tasks. Medicated severe PD patients were impaired on all three tests.

The above results are consistent with the results found by Postle *et al* (54), who assessed mild medicated PD patients on a visual delayed-response test with a spatial condition and a (non-spatial) object condition. Two stimuli were presented on the screen and after a 3-s. delay a test stimulus was displayed. The subject was required to judge whether this test stimulus matched one of the two stimuli in either spatial location or featural identity. A selective spatial delayed response deficit in PD was observed relative to matched control subjects. Similarly, the same group (55) found a selective deficit in a spatial condition, but not in an object condition of a conditional associative learning task in PD. In this task, subjects were shown two groups of stimuli, of which six appeared at the top and six appeared at the bottom of the screen. On each trial one of the top stimuli lit up and subjects were required to indicate which, one of the bottom stimuli had been paired with that top stimulus. PD patients needed more trials to achieve criterion (18 consecutive correct selections), learned at a slower rate and made more WM errors¹

In another recent study (56) the nature of the visuospatial memory deficit in PD was evaluated. Their question was whether the deficit was

1. Working memory errors were measured by the number of responses within a single trial in which a subject returned to a previously selected incorrect stimulus.

domain specific (spatial, verbal or visual) or related to strategic processes. In one experiment mild non-medicated and medicated PD patients and control subjects were assessed on a conditional associative learning task, which consisted of both a visuospatial and a verbal condition. In the spatial condition the learning by trial and error of arbitrary associations between 6 designs and locations on a matrix was required, while in the verbal condition the learning of associations between 6 animal names and arbitrary given names was required. Both non-medicated and medicated PD patients performed worse on both conditions compared to control subjects. In another experiment a 'non-strategic' condition, in which visuospatial associative links were externally guided, was compared to a 'strategic' condition, in which subjects had to elaborate a visuospatial representation on the basis of partial information. Both non-medicated and medicated PD patients performed worse on the 'non-strategic' condition than controls, but not on the 'strategic' condition. From these results, the authors concluded that the deficit was not domain-specific, but strategy-related.

Together these results have important implications for the progression of cognitive deficits in PD. While mild PD seems to be related to a decline in those functions probably mediated by the frontal lobes, such as spatial WM and strategic control, severe PD seems to be related to a decline in more basic (spatial, visual as well as verbal) mnemonic functions that are mediated by posterior cortical structures. These findings are consistent with the anatomical findings that dopamine depletion in PD is most severe in the dorsal rostral portion of the head of the caudate nucleus, which is anatomically connected to the dorsolateral prefrontal cortex and the posterior parietal lobe, and progresses to the more ventral portions of the caudate nucleus, which is thought to be connected to the ventrolateral prefrontal cortex and the temporal lobe (28,31,57,58).

In the study by Iddon *et al* (50), non-medicated PD patients were found to perform worse on all measures as compared to medicated PD patients. Many studies have found a beneficial effect of dopaminergic medication on certain cognitive functions (4,16,18,30). For example, Kulisevsky *et al* (20) found that the administration of levodopa after a 12 hour withdrawal period diminished response time in verbal and visuospatial memory tests. However, L-dopa administration did not affect the accuracy of performance. Lange *et al* (16) found that levodopa withdrawal selectively impaired spatial WM performance. Iddon *et al*'s finding (50) is also consistent with the hypothesis that levodopa alleviates WM deficits in PD.

NEURAL MECHANISMS UNDERLYING COGNITIVE IMPAIRMENTS IN PARKINSON'S DISEASE

Although dopaminergic neurotransmission in PD is most severely affected in the putamen and the caudate nucleus (via the nigro-striatal system), and depletion progresses only much later to frontal regions (via the mesocortical system, originating in the ventral tegmental area) (31,59)

many cognitive impairments are already seen on so-called 'frontal' tasks in the early stages of the disease. Thus, impairments in attentional set-shifting, such as specific EDS deficits, as measured using the ID/ED task and task-set switching deficits, have been found both in patients with frontal lobe damage and mild PD patients (13-17). In addition, impairments in (spatial) WM have been shown to be strategy-related in PD, as was found in patients with frontal lobe damage (50,51,56). Similarly, impairments are found on the Tower of London planning task in both patients with PD and frontal lobe damage (15,44,48). However, although the pattern of cognitive deficits is similar in PD and frontal lobe damage, subtle qualitative differences have been found, particularly on the Tower of London task, on the self-ordered WM task, on reversal and from an analysis of the underlying mechanisms of attentional set-shifting (perseveration versus learned irrelevance).

A possible role of dopamine in cognitive functioning was investigated directly by Mehta *et al* (19), who studied the effect of the dopaminergic D2 antagonist sulpiride, (with the striatum as its presumed major site of action), on a battery of tests. Following sulpiride, impairments were found on a spatial recognition test, a test of spatial WM (sequence generation), a version of the Tower of London planning task and the ID/ED shift task. The overall pattern of deficits was very similar to the pattern found in PD patients. It was suggested that the cognitive impairment seen in PD is partly dependent on dopamine D2 receptors, probably in the striatum. It has been frequently shown that dopaminergic medication either beneficially or detrimentally affects 'frontal' cognitive performance in PD (4,16,18-20,26,30). Because the greatest dopamine depletion in PD is in the nigro-striatal projection (59), these effects indicate that striatal areas may be involved in these 'frontal' functions.

One development relevant to the understanding of the nature and neural substrate of cognitive shifting deficits in PD is the 'functional anatomical' model of Alexander *et al* (28). This model emphasises the concept of segregated cortico-basal ganglia-thalamo-cortical pathways (Fig. 2). Topographically segregated cortical areas project to the striatum and maintain their segregation to some extent within the striatum. The striatum receives projections from nearly the entire cortex, but its outflow, via the globus pallidus and the thalamus, is mostly restricted to portions of the frontal lobe. Particularly, the "dorsolateral prefrontal" circuit and the "lateral orbitofrontal" circuit are implicated in complex cognitive deficits in PD. Considerable evidence indicates significant functional differentiation between these regions (27,32,60). For example, Owen *et al* (14) found that patients with predominantly *dorsolateral* prefrontal lobe excisions were selectively impaired in the EDS stage, but not in reversal. Rahman *et al* (61) found patients with fronto-temporal dementia (in which damage is initially probably restricted to the *ventral* prefrontal cortex) to be impaired in reversal, but not in the EDS stage. The neural substrate of Huntington's disease is a *dorsal-to-ventral* progression of cell death in the striatum. Patients with Huntington's disease (as well as preclinical carriers of the mutation)

were found to be specifically impaired on ED shifting, but not on reversal shifting (21,22,29).

Taken together, the above-mentioned findings strongly indicate a dorsolateral fronto-striatal substrate for ED set-shifting. Together with the anatomical finding that dopamine depletion progresses from the dorsal to the ventral portions of the caudate nucleus, the specific EDS deficit found in PD suggests a dysfunction of dorsolateral prefrontal-striatal loops (28) rather than ventral or orbitofrontal-striatal loops in the brain.

Several recent studies, using positron emission tomography (PET), have provided evidence for (i) the involvement of fronto-striatal circuits in 'frontal' planning and WM tasks and (ii) striatal, but not directly frontal, involvement in the parkinsonian impairment in planning and WM. For example, in a study by Owen *et al* (62) a modified version of the Tower of London task was used to study easy and difficult planning in normal volunteers. On each trial two sets of three coloured circles ('balls'), one set at the top and one set at the bottom, were displayed on a touch-sensitive computer screen. The 'balls' in the top were arranged in a particular way in three 'pockets' and subjects were required to move 'balls' at the bottom of the screen to match this goal arrangement at the top of the screen. The subjects could move a 'ball' at the bottom of the screen between pockets by touching the 'ball' in the pocket and then touching one of the empty positions in one of the other pockets. A simple planning condition involved problems which required a minimum of 3 moves to make a correct match, while a difficult planning condition involved problems which required a minimum of 4 or 5 moves to make a correct match. A mnemonic variant of the task was used to study short-term retention and reproduction of problem solutions. On each trial, balls moved from pocket to pocket and subjects had to watch and repeat this series of moves, when the balls had returned to their original positions. Task difficulty was varied in a similar way to that of the planning task. A condition with identical stimuli and motor responses was included to control for visual perception and motor function. In this condition subjects were required to touch the 'ball' that was highlighted with a yellow ring. Regional cerebral blood flow was found to be increased in the left mid-dorsolateral frontal cortex and in the head of the caudate nucleus in the difficult planning condition, relative to the control condition. Bloodflow in the left caudate nucleus and the right thalamus was increased in the difficult planning condition, relative to the simple planning condition. Increased bloodflow was found in both the mid-dorsolateral frontal cortex as well as in ventral frontopolar regions when control conditions were subtracted from the memory conditions (simple and difficult). Ventral frontopolar regions were also increased in the difficult memory condition, relative to the difficult planning condition. Furthermore, increased activation was found in the right hippocampus when the difficult memory condition and the simple memory condition were subtracted. These results provide evidence for a role of frontostriatal circuitry in planning and spatial WM. They are also consistent with previous results demonstrating that planning deficits have been observed

in PD patients (15,48) and patients with frontal lobe damage (44). Moreover, impairments in patients with frontal lobe damage and temporal lobe damage on spatial WM tasks (45) are consistent with findings of frontal and hippocampal increases in activation in the memory condition.

One problem with the interpretation of findings from the above mentioned PET study arose from the subtraction of the effects of a visually cued control task from those of a cognitive planning task, which involved self-initiated movements. Evidence exists for involvement of the dorsolateral prefrontal cortex in self-initiated movements as opposed to externally triggered movements (63,64). Therefore, the frontal activation found previously in controls may have been a consequence of this characteristic of the cognitive planning task. In a study by Dagher *et al* (65) this limitation was overcome by using a correlational design and comparing these results with a categorical design, in which a rest condition was subtracted from the task-conditions. The dorsolateral prefrontal cortex, the lateral premotor cortex, the rostral anterior cingulate cortex and the caudate nucleus were identified as areas involved in cognitive planning. These areas correlated with task-complexity, as defined by the number of moves required to solve a problem. In contrast, other areas (the supplementary motor area, the caudal anterior cingulate cortex and the putamen and areas in the dorsal visual processing stream) were activated when task conditions were compared to the rest condition, but these areas did not correlate with task-complexity. Therefore, it was concluded that these areas are involved in the production of motor output and the processing of visual input, but not in cognitive planning *per se*. In conclusion, bloodflow changes in fronto-striatal areas have repeatedly been shown during performance of 'frontal' tasks in healthy volunteers (62,65,66).

In a later PET study Owen *et al* (67) went on to compare PD patients with control subjects on exactly the same tasks. Dopaminergic medication was withdrawn for at least 12 hours in the patients. The four main comparisons were the difficult planning condition versus the visuomotor control condition, the difficult planning condition versus the simple planning condition, the difficult memory condition versus the control condition and the difficult memory condition versus the simple memory condition. During both planning and memory, activation was found to be consistently *increased* in control subjects and consistently *decreased* in PD patients in one specific region: the internal segment of the right globus pallidus. This finding was replicated in a study in which six more PD patients were scanned (Owen *et al*, unpublished data). Similar bloodflow changes in the mid-dorsolateral frontal cortex were observed in control subjects and PD patients. These results provided direct evidence for a disruption of fronto-striatal loop functioning by striatal dopamine depletion. Thus, the 'frontal' deficit of PD patients in the Tower of London task appears to result from striatal, rather than frontal, dysfunctioning.

The above mentioned PET studies, in which the Tower of London was used, were followed up by a third study (Owen *et al*, unpublished data), comparing PD patients, who were taking dopaminergic medication, with

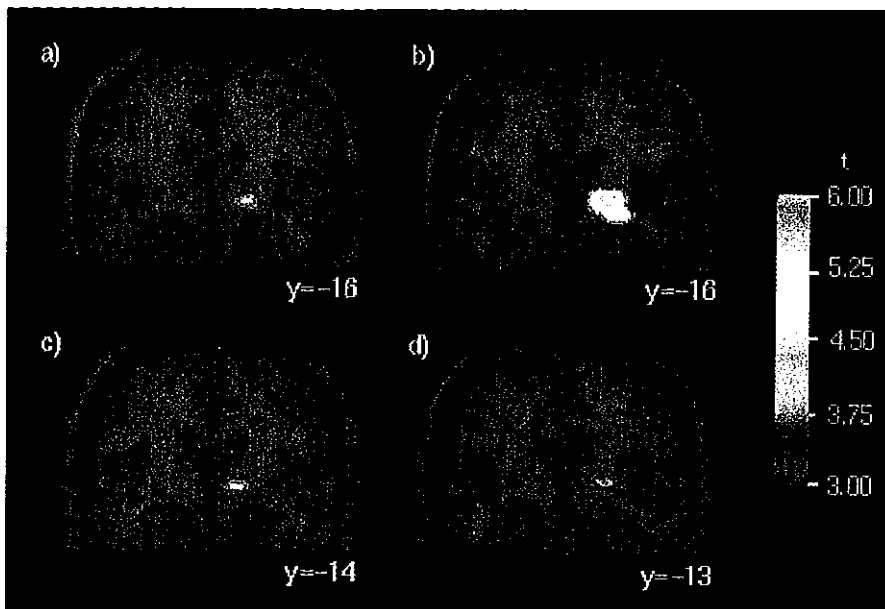

Fig. 5. The averaged PET subtraction images are shown superimposed upon the corresponding averaged MRI scan of all twelve subjects participating in the study. Direct comparisons between the six patients and the six control subjects yielded the focal differences in blood flow shown as a t-statistic image, whose range is coded by the colour scale placed to the right of the figure. In all four coronal sections, the y coordinates represents the position relative to the anterior commissure (positive/anterior) and has been chosen to illustrate the statistically significant difference in the region of the right GPi, between the control subjects and the PD patients when a) The Difficult Planning condition was compared to the Visuomotor Control condition ('Difficult Planning minus Visuomotor Control'), b) The Difficult Planning condition was compared to the Simple Planning condition ('Difficult Planning minus Simple Planning'), c) The Difficult Spatial Working Memory condition was compared to the Visuomotor Control condition ('Difficult Spatial Working Memory minus Visuomotor Control'), and d) The Difficult Spatial Working Memory condition was compared to the Simple Spatial Working Memory condition ('Difficult Spatial Working Memory minus Simple Spatial Working Memory'). The subjects left is on the left of the figure.

PD patients, whose medication was withdrawn. Preliminary results again suggest decrease in bloodflow in the right globus pallidus, when patients were in their on-medication state, relative the same patients in their off-medication state. Furthermore, differences in bloodflow were also observed between the on-medication state and the off-medication state in the left globus pallidus. However, this difference was in the opposite direction to that observed previously. An increase was found when patients were in their on-medication state, relative to their off-medication state. Other significant bloodflow changes with administration of levodopa were found in the premotor cortex, while decreases were observed in the hippocampus. Due to the inherent low statistical power of such designs it was not yet possible to

draw any definite conclusions regarding the task by group interaction effects of bloodflow changes. The relative increase in bloodflow in the left globus pallidus, when patients were in their on-medication state, relative to their off-medication state seems to be compatible with the finding of a relative decrease in the right globus pallidus during planning and memory condition in PD patients compared to controls, as was found in the previous study. However in the previous study the change was lateralised to the right hemisphere instead of in the left hemisphere. A decrease in the right globus pallidus in the on-medication state, relative to the off-medication state, on the other hand, seems to be compatible with current theories of an overactive internal globus pallidus in PD (68).

CONCLUSION

Cognitive impairments in PD in attentional set-shifting, task-set switching, working memory and strategy use and finally, Tower of London planning, resemble impairments in patients with frontal lobe lesions. However, qualitative differences have been found between these two patient groups on several tasks. The finding that dopaminergic medication affects performance on these tasks in PD, together with the anatomical finding that dopamine transmission is most severely depleted in the striatum, suggests fronto-striatal underlying mechanisms of these cognitive deficits. The reviewed PET studies confirm the involvement of these loops in several cognitive tasks and suggest mainly striatal involvement in the parkinsonian impairment. The approach we have undertaken has proved useful in delineating the differential aspects and subcomponents of the cognitive impairment in PD (enhanced learned irrelevance, but not increased perseveration in medicated PD patients; probabilistic and concurrent reversal and learning impairments, but not simple reversal and learning impairments; set-switching impairments independent of set-formation; strategy use impairments in self-ordered working memory tasks) and in identifying the underlying neural mechanisms. Elucidating these factors will enhance our understanding of important clinical issues in PD, such as the effect of medication on cognitive functions, as well as improving our understanding of the functions of the basal ganglia.

ACKNOWLEDGEMENTS

This research was supported by a programme grant from the Wellcome Trust, by a Dutch-British Partnership Award to RC, by a studentship to RC from the Parkinson's Disease Society UK and by an MRC Research Studentship to RS

REFERENCES

1. Owen AM, Robbins TW. Comparative neuropsychology of parkinsonian syndromes. In: Wolters ECh, Scheltens P, eds. *Mental Dysfunction in Parkinson's Disease*. Dordrecht, ICG Printing, 1993:221-242.
2. Shallice T. Specific impairments of planning. *Phil Trans Royal Society London B* 1982;298:199-209.
3. Milner B. Effects of different lesions on card sorting. *Arch Neurol* 1963;9:100-110.
4. Bowen FP, Kamienny MA, Burns MM, Yahr MD. Parkinsonism: Effects of levodopa treatment on concept formation. *Neurology* 1975;25:701-704.
5. Lees AJ, Smith E. Cognitive deficits in the early stages of Parkinson's disease. *Brain* 1983;106:257-270.
6. Cools AR, Van den Bercken JHL, Horstink MWI, Van Spaendonck KPM, Berger HJC. Cognitive and motor shifting aptitude disorder in Parkinson's disease. *J Neurol Neurosurg Psychiatry* 1984;47:443-453.
7. Taylor AE, Saint-Cyr JA, Lang AE. Frontal lobe dysfunction in Parkinson's disease. *Brain* 1986;109: 845-883.
8. Brown RG, Marsden CD. "Subcortical dementia": The neuropsychological evidence. *Neuroscience* 1988;25:363-387.
9. Brown RG, Marsden CD. Internal versus external cues and the control of attention in Parkinson's disease. *Brain* 1988;111: 323-345.
10. Robertson C, Flowers KA. Motor set in Parkinson's disease. *J Neurol Neurosurg Psychiatry* 1990;53: 583-592.
11. Downes JJ, Sharp HM, Costall BM, Sagar HJ, Howe J. Alternating fluency in Parkinson's disease. *Brain* 1993;16:887-902.
12. Van Spaendonck KPM, Berger HJC, Horstink MWI, Borm GF, Cools AR. Card sorting performance in Parkinson' disease: A comparison between acquisition and shifting performance. *J Clin Exp Neuropsychol* 1995;17:918-925.
13. Downes JJ , Roberts AC, Sahakian BJ, Evenden JL, Morris RG, Robbins TW. Impaired extra-dimensional shift performance in medicated and unmedicated Parkinson's disease: evidence for a specific attentional dysfunction. *Neuropsychologia* 1989;27:1329-1343.
14. Owen AM, Roberts AC, Polkey CE, Sahakian BJ, Robbins TW. Extra-dimensional versus intra-dimensional set-shifting performance following frontal lobe excisions, temporal lobe excisions or amygdalo-hippocampectomy in man. *Neuropsychologia* 1991;29:993-1006.
15. Owen AM, James M, Leigh PN, et al. Fronto-striatal cognitive deficits at different stages of Parkinson's disease. *Brain* 1992;115:1727-1751.
16. Lange KW, Robbins TW, Marsden CD, James M, Owen AM, Paul GM. L-Dopa withdrawal in Parkinson's disease selectively impairs cognitive performance in tests of frontal lobe function. *Psychopharmacology* 1992;107:394-404.
17. Cools R. Mechanisms of task-set switching in Parkinson's disease. *M.Phil.Thesis, University of Cambridge* 1999.
18. Berger HJC, Van Hoof JJM, Van Spaendonck KPM, et al. Haloperidol and cognitive shifting. *Neuropsychologia* 1989;5:629-639.
19. Mehta MA, Sahakian BJ, McKenna PJ, Robbins TW. Systemic sulpiride in young adult volunteers simulates the profile of cognitive deficits in Parkinson's disease.

- Psychopharmacology* 1999, In Press.
20. Kulisevsky J, Avila A, Barvanoj M, Antonijoan R, Berthier ML, Gironell A. Acute effects of levodopa on neuropsychological performance in stable and fluctuating Parkinson's disease patients at different levodopa plasma levels. *Brain* 1996;119:2121-2132.
 21. Lawrence AD, Sahakian BJ, Hodges JR, Rosser AE, Lange KW, Robbins TW. Executive and mnemonic functions in early Huntington's disease. *Brain* 1996;119:1633-1645.
 22. Lawrence AD, Hodges JR, Rosser AE *et al.* Evidence for specific cognitive deficits in preclinical Huntington's disease. *Brain* 1998;121:1329-1341.
 23. Owen AM, Roberts AC, Hodges JR, Summers BA, Polkey CE, Robbins TW. Contrasting mechanisms of impaired attentional set-shifting in patients with frontal lobe damage or Parkinson's disease. *Brain* 1993;116:1159-1179.
 24. Gauntlett-Gilbert J, Roberts RC, Brown VJ. Mechanisms underlying attentional set-shifting in Parkinson's disease. *Neuropsychologia* 1999;37:605-616.
 25. Joosten JPA, Coenders CJK, Eling PATM. Shifting Behavior: An analysis of response patterns of Parkinson patients in discrimination learning. *Brain Cogn* 1995;29:115-126.
 26. Swinson R, Rogers R, Sahakian BJ, Summers BA, Polkey CE, Robbins TW. Probabilistic learning and reversal deficits in patients with Parkinson's disease or frontal or temporal lobe lesions: possible adverse effects of dopaminergic medication. Submitted.
 27. Dias R, Robbins TW, Roberts AC. Dissociation in prefrontal cortex of affective and attentional shifts. *Nature* 1996;380:69-72.
 28. Alexander GE, DeLong MR, Strick PL. Parallel organization of functionally segregated circuits linking basal ganglia and cortex. *Annu Rev Neurosci* 1986;9:357-381.
 29. Lange KW, Sahakian BJ, Quinn NP, Marsden CD, Robbins TW. Comparison of executive and visuospatial function in Huntington's disease and dementia of the Alzheimer-type matched for degree of dementia. *J Neurol Neurosurg Psychiatry* 1995;58:598-606.
 30. Gotham AM, Brown RG, Marsden CD. "Frontal" cognitive functions in patients with Parkinson's disease "on" and "off" levodopa. *Brain* 1988;111:299-321.
 31. Kish S J, Shannak K, Hornykiewicz O. Uneven patterns of dopamine loss in the striatum of patients with idiopathic Parkinson's disease. Pathophysiologic and clinical implications. *N Engl J Med* 1988;318:876-880.
 32. Rogers TD, Andrews TC, Grasby PM, Brooks DJ, Robbins TW. Contrasting cortical and sub-cortical activations produced by attentional set-shifting and reversal learning in humans. *J Cogn Neurosci* 1999, in press.
 33. Cooper JA, Sagar H, Jordan N, Harvey NS, Sullivan EV. Cognitive impairment in early, untreated Parkinson's disease and its relationship to motor disability. *Brain* 1991;114:2095-2122.
 34. Knowlton BJ, Mangels JA, Squire LR. A neostriatal habit learning-system in humans. *Science* 1996;273:1399.
 35. Canavan AGM, Passingham RE, Marsden CD, Quinn N, Wyke M, Polkey CE. The performance on learning tasks of patients in the early stages of Parkinson's disease. *Neuropsychologia* 1989;27:141-156.
 36. Swinson R. Cognitive flexibility and learning in Parkinson's disease. *PhD thesis, Cambridge University* 1998.
 37. Petrides M. Deficits on conditional associative tasks after frontal and temporal-lobe

- lesions in man. *Neuropsychologia* 1985;23:601-614.
38. Wise SP, Murray EA, Gerfen GR. The frontal cortex-basal ganglia system in primates. *Crit Rev Neurobiol* 1996;10:317-356.
 39. Robbins TW, Brown VJ. The role of the striatum in the mental chronometry of action: a theoretical review. *Rev Neurosci* 1991;2:181-213.
 40. Jersild AT. Mental set and shift. *Arch Psychol* 1927;89.
 41. Rogers RD, Monsell S. Costs of a predictable switch between simple cognitive tasks. *J Exp Psychol* 1995;24:207-231.
 42. Rogers RD, Sahakian BJ, Hodges JR, Polkey CE, Kennard C, Robbins TW. Dissociating executive mechanisms of task control following frontal lobe damage and Parkinson's disease. *Brain* 1998;121:815-842.
 43. Hayes AE, Davidson MC, Keele SW, Rafal RD. Toward a functional analysis of the basal ganglia. *J Cogn Neurosci* 1998;10:178-198.
 44. Owen AM, Downes JD, Sahakian BJ, Polkey CE, Robbins TW. Planning and spatial working memory following frontal lobe lesions in man. *Neuropsychologia* 1990;28:1021-1034.
 45. Owen AM, Morris RG, Sahakian BJ, Polkey CE, Robbins TW. Double dissociations of memory and executive functions in working memory tasks following frontal lobe excisions, temporal lobe excisions or amygdalo-hippocampectomy in man. *Brain* 1996;119:1597-1615.
 46. Owen AM, Beksinska M, James M, et al. Visuospatial memory deficits at different stages of Parkinson's disease. *Neuropsychologia* 1993;31:627-644.
 47. Owen AM. The functional organisation of working memory processes within human lateral frontal cortex: The contribution of functional imaging. *Eur J Neurosci* 1997;9:1329-1339.
 48. Owen AM, Sahakian BJ, Hodges JR, Summers BA, Polkey CE, Robbins TW. Dopamine-dependent fronto-striatal planning deficits in early Parkinson's disease. *Neuropsychology* 1995;9:126-140.
 49. Buytenhuis EL, Berger HJ, Van Spaendonck KPM, Horstink MWI M, Borm GF, Cools AR. Memory and learning strategies in patients with Parkinson's disease. *Neuropsychologia* 1994;32:335-342.
 50. Iddon JL, Swainson R, Sahakian BJ, Robbins TW. Mnemonic strategies in patients with frontal or temporal lobe excisions, Parkinson's disease and progressive supranuclear palsy. Submitted.
 51. West R, Winocur G, Ergis A, Saint-Cyr, J. The contribution of impaired working memory monitoring to performance of the self-ordered pointing task in normal ageing and Parkinson's disease. *Neuropsychology* 1998;12:546-554.
 52. Petrides M, Milner B. Deficits on subject-ordered tasks after frontal and temporal lobe lesions in man. *Neuropsychologia* 1982;20:249-262.
 53. Owen AM, Iddon JL, Hodges JR, Summers BA, Robbins TW. Spatial and non-spatial working memory at different stages of Parkinson's disease. *Neuropsychologia* 1997;35:519-532.
 54. Postle BR, Corlun S, Jonides J, Smith EE, Growdon JH. Spatial, but not object, delayed response is impaired in early Parkinson's disease. *Neuropsychology* 1997;11:171-179.
 55. Postle BR, Locascio JJ, Corlun S, Growdon JH. The time course of spatial and object learning in Parkinson's disease. *Neuropsychologia* 1999; in press.
 56. Pillon B, Deweer B, Vidailhet M, Bonnet A, Hahn-Barma V, Dubois B. Is impaired

- memory for spatial location in Parkinson's disease domain specific or dependent on 'strategic' processes? *Neuropsychologia* 1998;36:1-9.
57. Selemon LD, Goldman-Rakic PS. Longitudinal topography and interdigitation of corticostriatal projection in the rhesus monkey. *J Neurosci* 1985;5:776-794.
 58. Middleton FA, Strick PL. The temporal lobe is a target of output from the basal ganglia. *Proc Natl Acad Sci* 1996;93:8683-8687.
 59. Agid Y, Javoy-Agid F, Ruberg M. Biochemistry of neurotransmitters in Parkinson's disease. In: Marsden CD, Fahn S, eds. *Biochemistry of neurotransmitters in Parkinson's disease*. London, Butterworth 1987: 166-230.
 60. Robbins TW, Everitt BJ. Functions of dopamine in the dorsal and ventral striatum. In: Robbins TW, ed. *Seminars in the Neurosciences*. London, Saunders, 1992:119-127.
 61. Rahman S, Sahakian BJ, Hodges JR, Rogers RD, Robbins TW. Specific cognitive deficits in mild frontal variant frontotemporal dementia. *Brain* 1999, in press.
 62. Owen AM, Doyon J, Petrides M, Evans AC. Planning and spatial working memory: a Positron Emission Tomography study in humans. *Eur J Neurosci* 1996;8:353-364.
 63. Jahanshahi M, Jenkins IH, Brown RG, Marsden CD, Passingham RE, Brooks DJ. Self-initiated versus externally triggered movements. An investigation using measurement of regional cerebral blood flow with PET and movement-related potentials in normal and Parkinson's disease subjects. *Brain* 1995;118:913-933.
 64. Playford ED, Jenkins IH, Passingham RE, Nutt J, Frachowiack RSJ, Brooks DJ. Impaired mesial frontal and putamen activation in Parkinson's disease: a positron emission tomography study. *Ann Neurol* 1992;32:151-161.
 65. Dagher A, Owen AM, Boecher H, Brooks DJ. Mapping the network for planning: A correlational PET activation study with the Tower of London task. *Brain* 1999, in press.
 66. Baker SC, Rogers RD, Owen AM, et al. Neural systems engaged by planning: A PET study of the Tower of London task. *Neuropsychologia* 1996;34:515-526.
 67. Owen AM, Doyon J, Dagher A, Sadikot A, Evans AC. Abnormal basal ganglia outflow in Parkinson's disease identified with PET: Implications for higher cortical functions. *Brain* 1998;121:949-965.
 68. DeLong MR. Primate models of movement disorders of basal ganglia origin. *Trends Neurosci* 1990;13:281-285.